

SafeGuard-BR system

A lockable intubation adapter system for safe respiratory tract access against infection and contamination

Invention

Patients with infectious respiratory diseases especially COVID-19 patients, often require an artificial pressure-controlled respiration and examination of the respiratory tract. These measures lead to direct contact between hospital staff and patients' airways, which could potentially increase the risk of contamination and infection through the release of infectious aerosols.

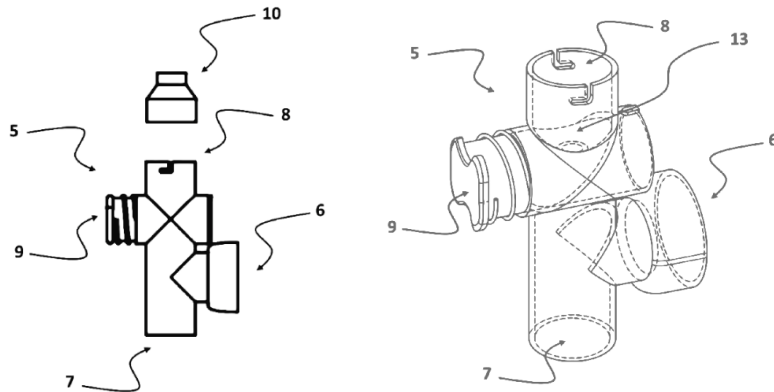

The present invention solves an urgent medical need by providing a lockable intubation adapter system 5 designed to improve airway access during medical examinations, and to minimize the risks of infection and contamination

The present invention solves an urgent medical need by providing a lockable intubation adapter system 5 designed to improve airway access during medical examinations, and to minimize the risks of infection and contamination.

The system comprises the intubation adapter system 5, which has a receptacle 6 for the ventilation device and a receptacle 7 for the endotracheal tube 3. It might be beneficial to consider the possibility of shutting off the two receptacles from the receptacle 8 towards the examination instrument with the help of the shut-off device 9. Additionally, an adapter attachment 10 may be fitted for other instruments. The shut-off device 9 is cylindrical in shape and has a central passage with a lockable device. It is designed to allow a cylindrical examination instrument to be guided or pushed through the seals in a gas-tight manner. When the shut-off device 9 is locked, it can be used to attach instruments to the openings of 6, 7 and 8, thus preventing the release of infectious aerosols into the treatment environment.

Commercial Opportunities

This invention provides a lockable intubation adapter system that allows hygienic, protected performance of intensive-care examinations without releasing infectious aerosol particles or droplets into the ambient atmosphere.

Current Status

A prototype is available.

Relevant Publications

Koehler P., et al., Mycoses. 2021 Jan;64(1):55-59.

An invention from the University Hospital Cologne.

Competitive Advantages

- Allows hygienic work during artificial respiration and bronchoscopies
- Protects health personnel from infection
- Avoids contamination of the environment
- Compatible with different respiratory devices
- Configuration of the device permits the administration of treatments to the patient without the loss of pressure that would otherwise occur during ventilation

Technology Readiness Level

1 2 3 4 5 6 7 8 9

Technology validated in relevant environment

Industries

- Medical Technology

Ref. No.

6067

Contact

Prof. Frank Entschladen
E-Mail: fe@provendis.info
Phone: +49(0)208-94105-20

